

COLLINS WORKALL®

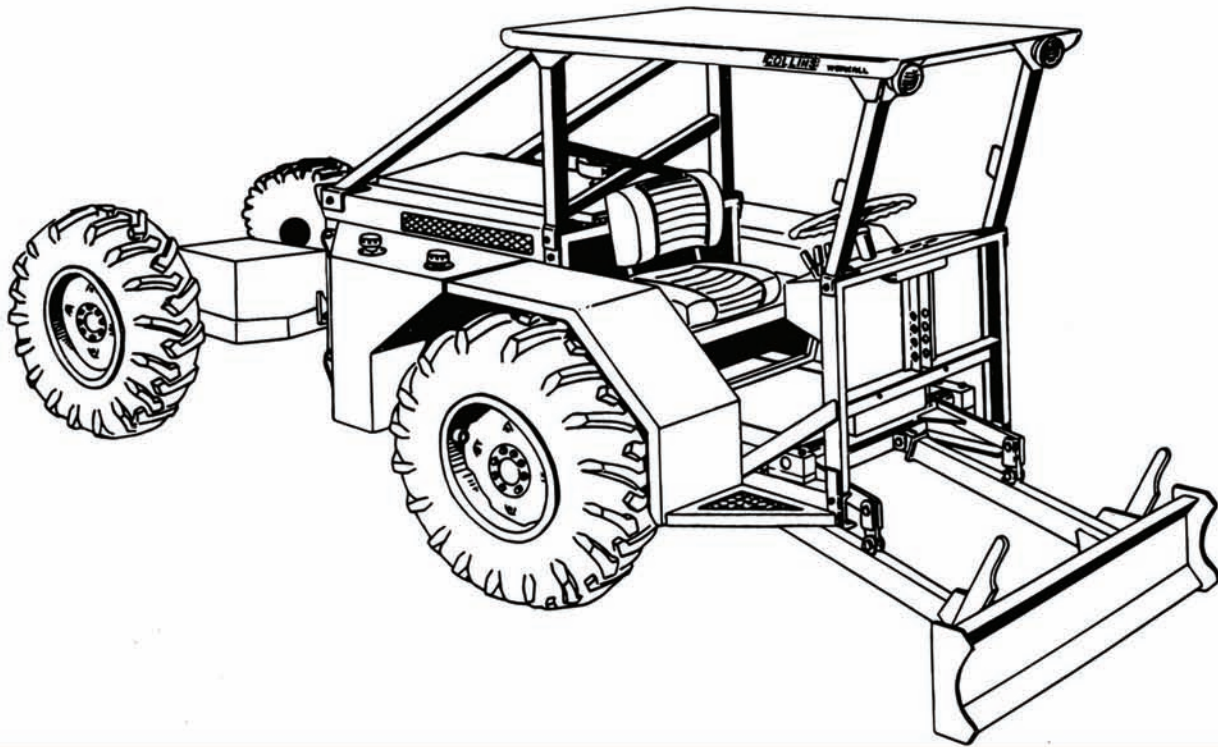

WORKALL is the ONE versatile tractor designed for your Forestry, Construction, and Agricultural needs.



The **COLLINS WORKALL®** is the ONE versatile tractor designed for your forestry, construction, and agricultural needs. **WORKALL®** can be used with standard farm attachments, as a small skidder, dump truck, loader, backhoe, snowblower, mower, forklift, rototiller, eliminating the need for many single purpose machines. The tip-resistant oscillating and articulating center joint keeps all four wheels on the ground, combined with the **WORKALL®**'s narrow width, equal weight distribution, and excellent maneuvering characteristics makes this safe, conservation-friendly tractor ideal for use in rugged, hilly New England terrain.

The **COLLINS WORKALL®** tractor is ideal for challenging jobs, for example:

- Eco-Friendly Forestry, Farming
- Small Scale Forestry Operations
- Landowners who don't want to own and Maintain Multiple Machines
- Rough Terrain Mowing
- Forestry Firefighting and Municipal Utility Work
- Job limited only by owner's creativity!

The **COLLINS WORKALL®** tractor is Engineered from the Ground Up!

- Horsepower - Continuous 73 - Diesel or Gas
- Tire size: 12.4 x 24 Agricultural Tread
- Transmission - Hydrostatic
- Tanks Capacities: 23 U.S. Gallons
- Steering: Hydraulic - Two Cylinders
- Weight: +/- 9000 lbs. with Flat Stake Body and Front Blade

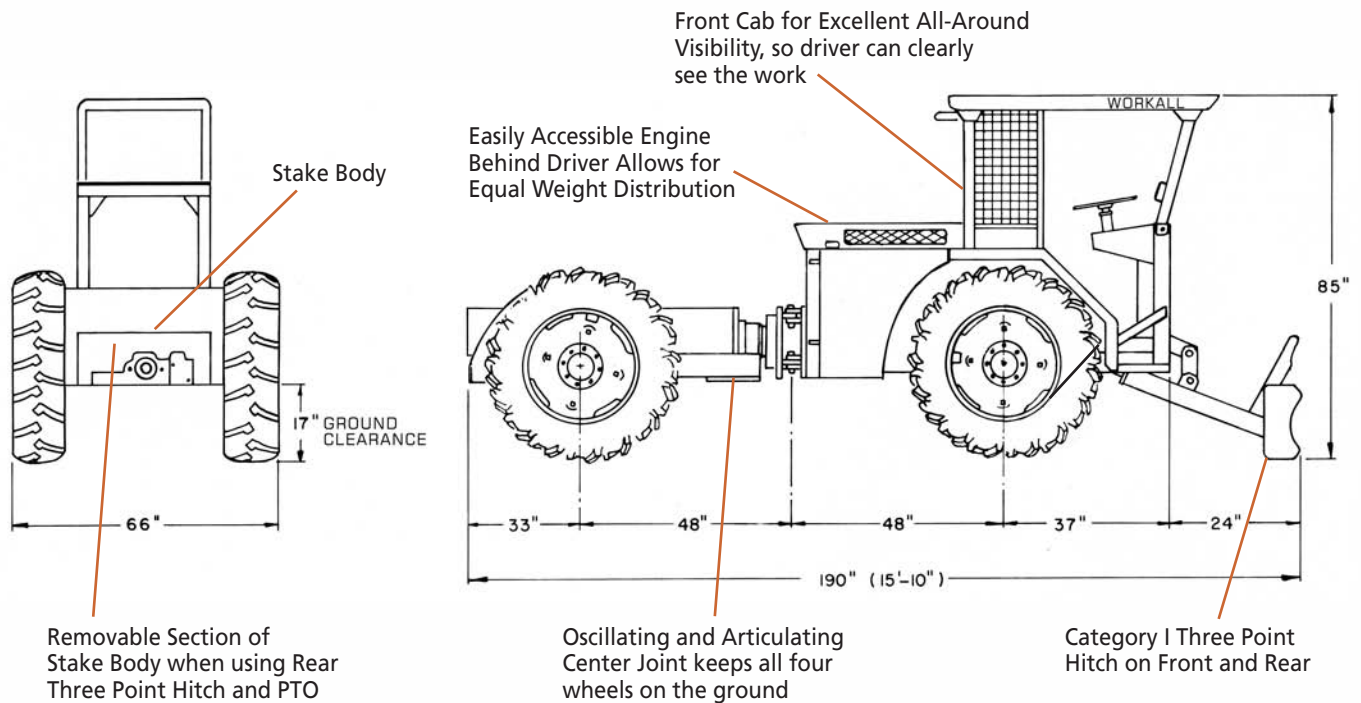

STANDARD FEATURES:

- Foot controlled hydrostatic four wheel drive. 4 individual wheel motors
- Infinitely variable speed. 0-13 mph
- Center articulating and oscillating
- Full instrument panel
- Lights front and rear
- Enclosed cab with ROPS/FOPS/OPS
- Live PTO - 40 HP - front and rear (not both at same time)
- Auxiliary Disconnects (2) on front and rear
- Flat Body with slots for stakes - removable section when using three point hitch

OPTIONS:

- Diesel Engine 73 HP
- Gas Engine 73 HP
- Dump Cylinder and connections
- Quick Attach Plate - Category I (Skid Steer equipment up to HP rating of Mfg)
- Heater
- Air Conditioner
- Back-up Camera



COLLINS WORKALL®

Nelson Tractor LTD. Maury Collins



521 Old Stoddard Road, Nelson, NH 03457 Tel: 603-847-3321 www.workall.com